

NX5L2750C

Analog switch with negative swing audio capability

Rev. 1 — 6 September 2013

Product data sheet

1. General description

The NX5L2750C is a dual low-ohmic single-pole double-throw analog switch suitable for use as an analog or digital 2 : 1 multiplexer/demultiplexer. Each switch has a digital select input (nS), two independent inputs/outputs (nY0 and nY1) and a common input/output (nZ).

The NX5L2750C is capable of switching audio signals with negative swing without the need of a coupling capacitor.

Schmitt trigger action at the digital inputs makes the circuit tolerant to slower input rise and fall times. Low threshold digital inputs allows this device to be driven by 1.8 V logic levels in 3.3 V applications without significant increase in supply current I_{CC} . This makes it possible for the NX5L2750C to switch 5 V audio signals with a 1.8 V digital controller, eliminating the need for logic level translation.

2. Features and benefits

- Supply voltage range from 1.8 V to 5.0 V
- 0.8 Ω typical ON resistance
- 100 MHz typical bandwidth or data frequency
- CMOS low-power consumption
- 1.8 V control logic at $V_{CC} = 3.6$ V
- Break-before-make switching
- ESD protection:
 - ◆ HBM JESD22-A114F Class 3A exceeds 4000 V
 - ◆ CDM AEC-Q100-011 revision B exceeds 1000 V
- Latch-up performance exceeds 100 mA per JESD 78 Class II Level A
- Specified from -40 °C to $+85$ °C

3. Applications

- Cellular phones, PDA
- Portable media players
- Personal media players



4. Ordering information

Table 1. Ordering information

Type number	Package			Version
	Temperature range	Name	Description	
NX5L2750CGU	-40 °C to +85 °C	XQFN10	plastic, extremely thin quad flat package; no leads; 10 terminals; body 1.40 × 1.80 × 0.50 mm	SOT1160-1

5. Marking

Table 2. Marking

Type number	Marking code
NX5L2750CGU	LA

6. Functional diagram

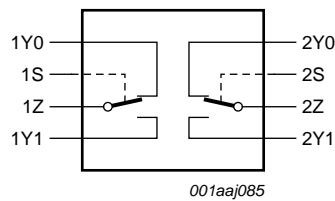

Fig 1. Logic symbol

7. Pinning information

7.1 Pinning

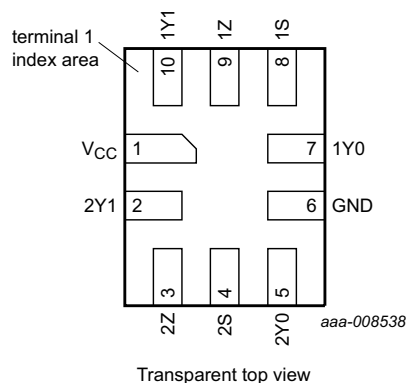

Fig 2. Pin configuration SOT1160-1 (XQFN10)

7.2 Pin description

Table 3. Pin description

Symbol	Pin	Description
V_{CC}	1	supply voltage
2Y0, 1Y0	5, 7	independent input or output
2Z, 1Z	3, 9	common output or input
2S, 1S	4, 8	select input
GND	6	ground (0 V)
2Y1, 1Y1	2, 10	independent input or output

8. Functional description

Table 4. Function table^[1]

Input	Channel on
nS	
L	nY0 = nZ
H	nY1 = nZ

[1] H = HIGH voltage level; L = LOW voltage level.

9. Limiting values

Table 5. Limiting values

In accordance with the Absolute Maximum Rating System (IEC 60134). Voltages are referenced to GND (ground = 0 V).

Symbol	Parameter	Conditions	Min	Max	Unit
V_{CC}	supply voltage		-0.5	+5.5	V
V_I	input voltage	pins nS	^[1] -0.5	+5.5	V
V_{SW}	switch voltage		-4.0	$V_{CC} + 0.5$	V
I_{IK}	input clamping current	$V_I < -0.5$ V	-50	-	mA
I_{SK}	switch clamping current	$V_I < -4.0$ V or $V_I > V_{CC} + 0.5$ V	-	± 50	mA
I_{SW}	switch current	$T_{amb} = 25$ °C	-	± 250	mA
		$T_{amb} = 25$ °C; peak current (pulsed at 1 ms duration; < 10 % duty cycle)	-	± 500	mA
I_{CC}	supply current		-	+50	mA
T_{stg}	storage temperature		-65	+150	°C
P_{tot}	total power dissipation	$T_{amb} = -40$ °C to +85 °C	-	250	mW

[1] The minimum input voltage rating may be exceeded if the input current rating is observed.

10. Recommended operating conditions

Table 6. Recommended operating conditions

Symbol	Parameter	Conditions	Min	Max	Unit
V_{CC}	supply voltage		1.8	5.0	V
V_I	input voltage	pins nS	0	5.0	V
V_{SW}	switch voltage		[1] -2.5	V_{CC}	V
T_{amb}	ambient temperature		-40	+85	°C

[1] The voltage across the switch should be < 5.5 V.

11. Static characteristics

Table 7. Static characteristics

At recommended operating conditions; voltages are referenced to GND (ground 0 V).

Symbol	Parameter	Conditions	$T_{amb} = -40\text{ °C to }+85\text{ °C}$			Unit
			Min	Typ ^[1]	Max	
V_{IH}	HIGH-level input voltage	$V_{CC} = 2.7\text{ V to }4.3\text{ V}$	1.4	-	-	V
V_{IL}	LOW-level input voltage	$V_{CC} = 2.7\text{ V to }4.3\text{ V}$	-	-	0.6	V
V_{IK}	input clamping voltage	$V_{CC} = 3.0\text{ V}; I_I = -18\text{ mA}$	-	-	-1.2	V
I_I	input leakage current	pins nS; $V_I = 0\text{ V to }V_{CC}$; $V_{CC} = 0\text{ V to }4.3\text{ V}$	-	-	± 1	μA
$I_{S(OFF)}$	OFF-state leakage current	$V_{CC} = 2.7\text{ V}; V_I = -2.5\text{ V or }2.5\text{ V};$ $V_O = 2.5\text{ V or }-2.5\text{ V};$ see Figure 3	-	-	± 250	nA
I_{CC}	supply current	$V_I = V_{CC}\text{ or GND}; V_{SW} = \text{GND or }V_{CC};$ $V_{CC} = 2.7\text{ V}$	-	-	2	μA
ΔI_{CC}	additional supply current	$V_I = 2.6\text{ V}; V_{SW} = \text{GND or }V_{CC};$ $V_{CC} = 4.3\text{ V}$	-	-	10	μA
		$V_I = 1.8\text{ V}; V_{SW} = \text{GND or }V_{CC};$ $V_{CC} = 4.3\text{ V}$	-	-	15	μA
C_I	input capacitance	pins nS	-	1.5	-	pF
$C_{S(OFF)}$	OFF-state capacitance	pins nY0 and nY1; $V_{CC} = 3.3\text{ V};$ $V_I = 0\text{ V to }3.3\text{ V}$	-	35	-	pF
$C_{S(ON)}$	ON-state capacitance	pins nZ; $V_{CC} = 3.3\text{ V}; V_I = 0\text{ V to }3.3\text{ V}$	-	75	-	pF

[1] Typical values are measured at $T_{amb} = 25\text{ °C}$ and $V_{CC} = 3.3\text{ V}$.

11.1 Test circuits

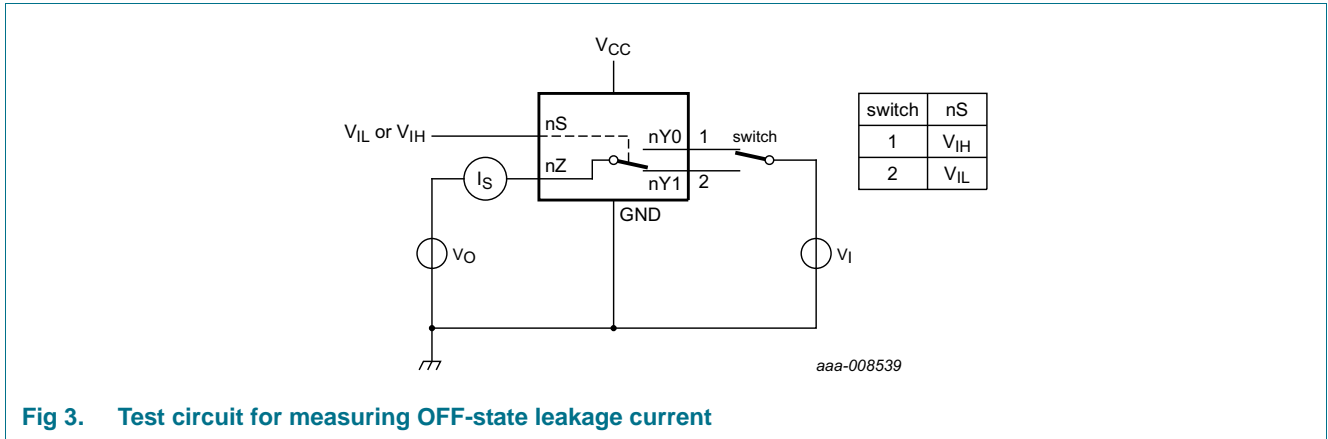

Fig 3. Test circuit for measuring OFF-state leakage current

11.2 ON resistance

Table 8. ON resistance

At recommended operating conditions; voltages are referenced to GND (ground = 0 V).

Symbol	Parameter	Conditions	-40 °C to +85 °C			Unit
			Min	Typ ^[1]	Max	
R _{ON}	ON resistance	V _I = V _{CC} -4.5 V to V _{CC} ; I _{SW} = 100 mA; V _{CC} = 2.7 V; see Figure 4	-	0.8	1.3	Ω
R _{ON(flat)}	ON resistance (flatness)	V _I = V _{CC} -4.5 V to V _{CC} ; I _{SW} = 100 mA; V _{CC} = 2.7 V; see Figure 4	-	0.3	-	Ω
ΔR _{ON}	ON resistance mismatch between channels	V _I = V _{CC} -4.5 V; I _{SW} = 100 mA; V _{CC} = 2.7 V; see Figure 4	-	0.1	-	Ω

- [1] Typical values are measured at T_{amb} = 25 °C.
- [2] Measured at identical V_{CC}, temperature and input voltage.

11.3 ON resistance test circuit and graphs

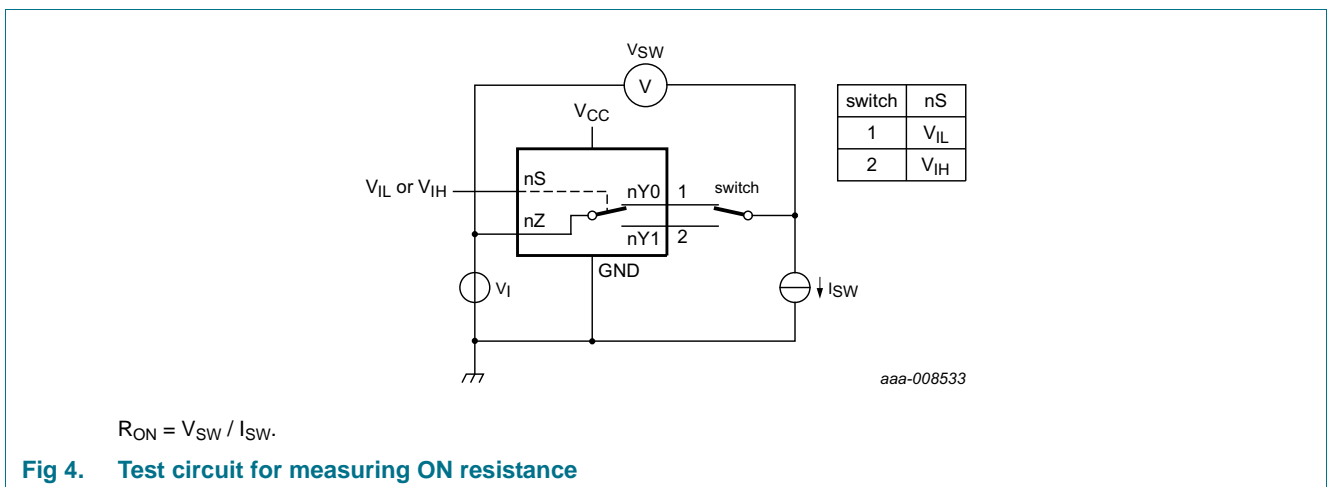

Fig 4. Test circuit for measuring ON resistance

12. Dynamic characteristics

Table 9. Dynamic characteristics

At recommended operating conditions; voltages are referenced to GND (ground = 0 V); for test circuit see [Figure 7](#).

Symbol	Parameter	Conditions	T _{amb} = -40 °C to +85 °C			Unit	
			Min	Typ ^[1]	Max		
t _{en}	enable time	nS to nZ; see Figure 5					
		V _{CC} = 2.7 V to 3.6 V	[2]	-	80	160	ns
		V _{CC} = 3.6 V to 4.3 V	[3]	-	70	120	ns
t _{dis}	disable time	nS to nZ; see Figure 5					
		V _{CC} = 2.7 V to 3.6 V	[2]	-	25	50	ns
		V _{CC} = 3.6 V to 4.3 V	[3]	-	25	50	ns
t _{b-m}	break-before-make time	see Figure 6	[4]				
		V _{CC} = 2.7 V to 3.6 V		15	55	-	ns
		V _{CC} = 3.6 V to 4.3 V		12	45	-	ns

- [1] Typical values are measured at T_{amb} = 25 °C.
- [2] Typical values are measured at V_{CC} = 3.3 V.
- [3] Typical values are measured at V_{CC} = 4.3 V.
- [4] Guaranteed by design.

12.1 Waveform and test circuits

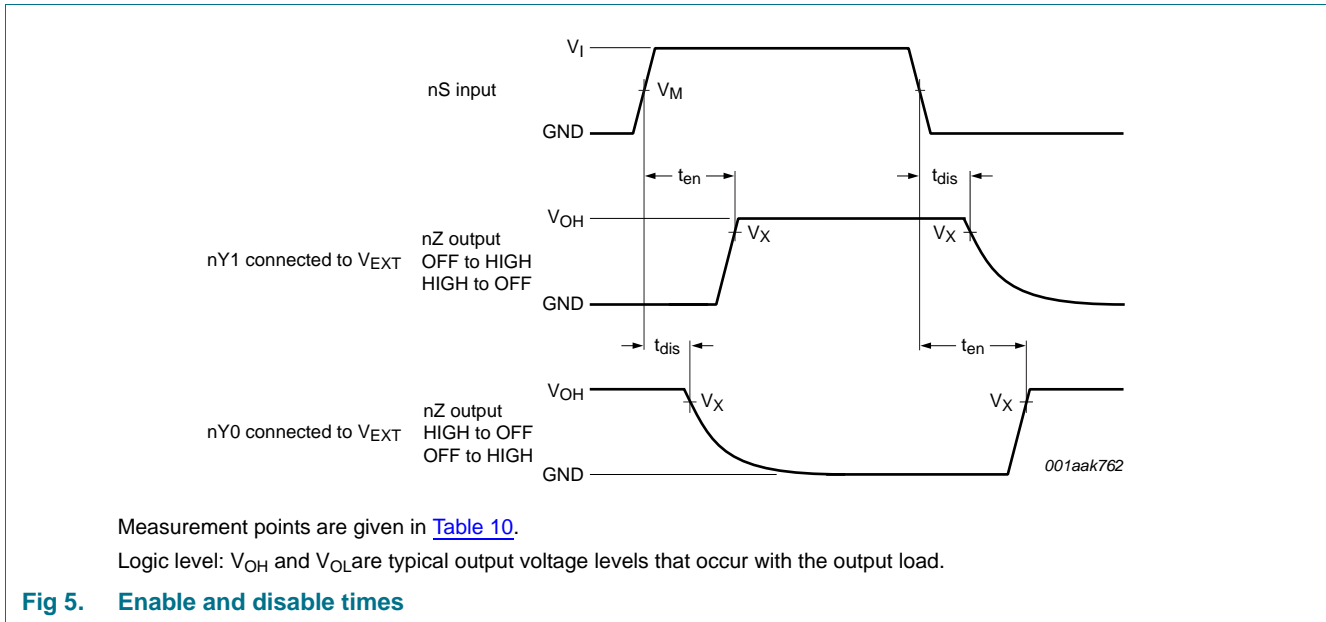

Table 10. Measurement points

Supply voltage	Input		Output
V _{CC}	V _M	V _I	V _X
2.7 V to 4.3 V	0.5V _{CC}	V _{CC}	0.9V _{OH}

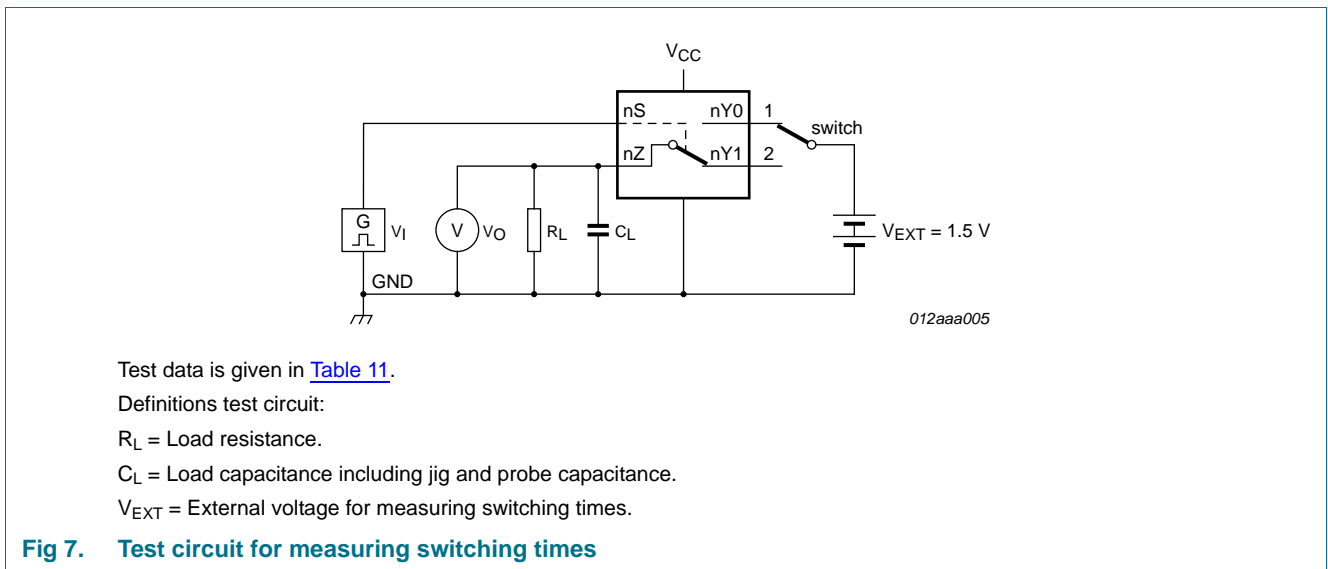
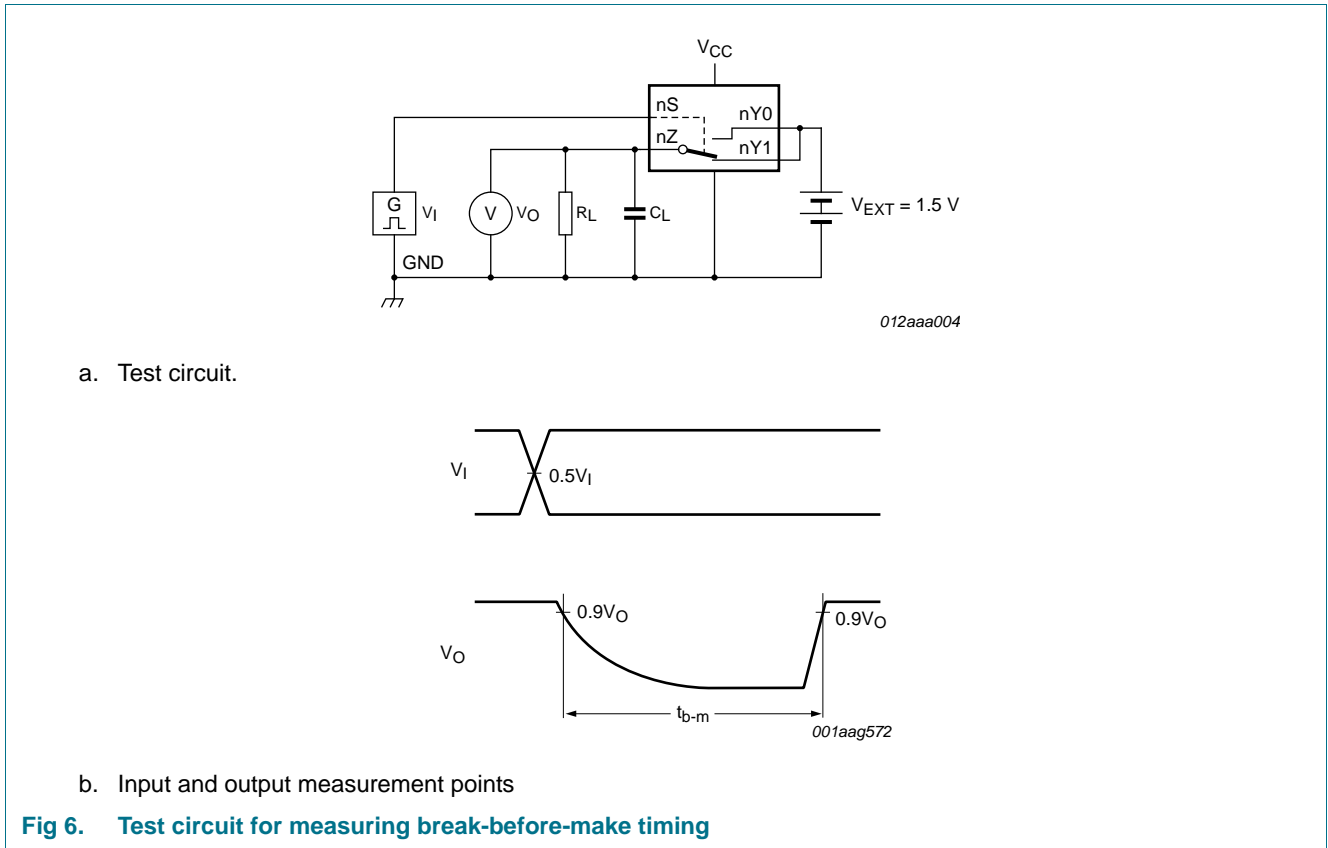

Table 11. Test data

Supply voltage	Input		Load	
V_{CC}	V_I	t_r, t_f	C_L	R_L
2.7 V to 4.3 V	V_{CC}	≤ 2.5 ns	35 pF	50 Ω

12.2 Additional dynamic characteristics

Table 12. Additional dynamic characteristics

At recommended operating conditions; voltages are referenced to GND (ground = 0 V); $V_I = GND$ or V_{CC} (unless otherwise specified); $t_r = t_f \leq 2.5$ ns; $T_{amb} = 25$ °C.

Symbol	Parameter	Conditions	Min	Typ	Max	Unit
THD	total harmonic distortion	$f_i = 20$ Hz to 20 kHz; $R_L = 32$ Ω ; see Figure 8				
		$V_{CC} = 2.7$ V; $V_I = 2$ V (p-p)	-	0.07	-	%
		$V_{CC} = 4.3$ V; $V_I = 2$ V (p-p)	-	0.03	-	%
$f_{(-3dB)}$	-3 dB frequency response	$R_L = 50$ Ω ; see Figure 9				
		$V_{CC} = 2.7$ V to 4.3 V	-	100	-	MHz
α_{iso}	isolation (OFF-state)	$f_i = 100$ kHz; $R_L = 50$ Ω ; see Figure 10				
		$V_{CC} = 2.7$ V to 4.3 V	-	-60	-	dB
Xtalk	crosstalk	between switches;				
		$f_i = 100$ kHz; $R_L = 50$ Ω ; see Figure 11				
		$V_{CC} = 2.7$ V to 4.3 V	-	-60	-	dB
Q_{inj}	charge injection	$f_i = 1$ MHz; $C_L = 0.1$ nF; $R_L = 1$ M Ω ; $V_{gen} = 0$ V; $R_{gen} = 0$ Ω ; see Figure 12				
		$V_{CC} = 2.7$ V	-	3	-	pC
		$V_{CC} = 3.3$ V	-	4	-	pC
		$V_{CC} = 4.3$ V	-	5	-	pC

12.3 Test circuits

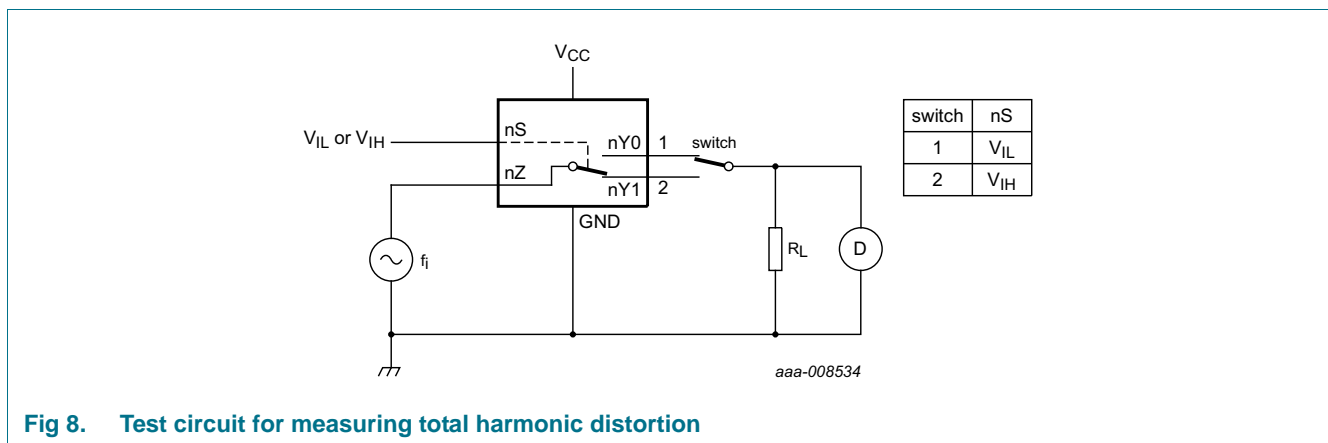
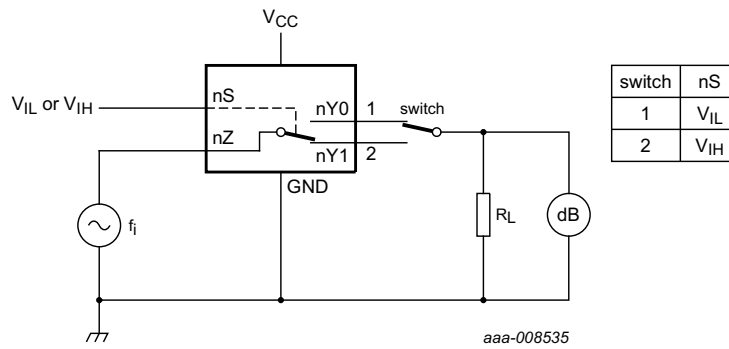
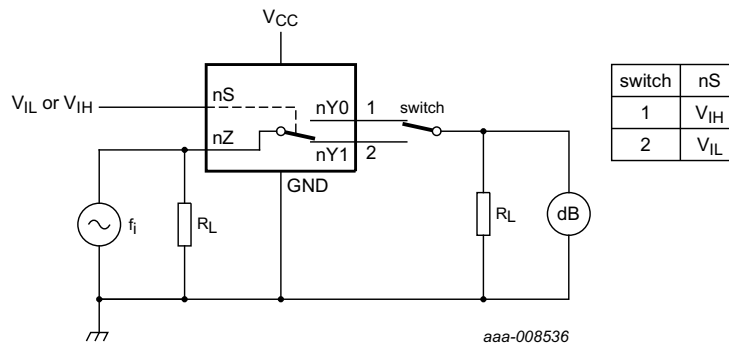

Fig 8. Test circuit for measuring total harmonic distortion



Adjust f_i voltage to obtain 0 dBm level at output. Increase f_i frequency until dB meter reads -3 dB.

Fig 9. Test circuit for measuring the frequency response when channel is in ON-state



Adjust f_i voltage to obtain 0 dBm level at input.

Fig 10. Test circuit for measuring isolation (OFF-state)

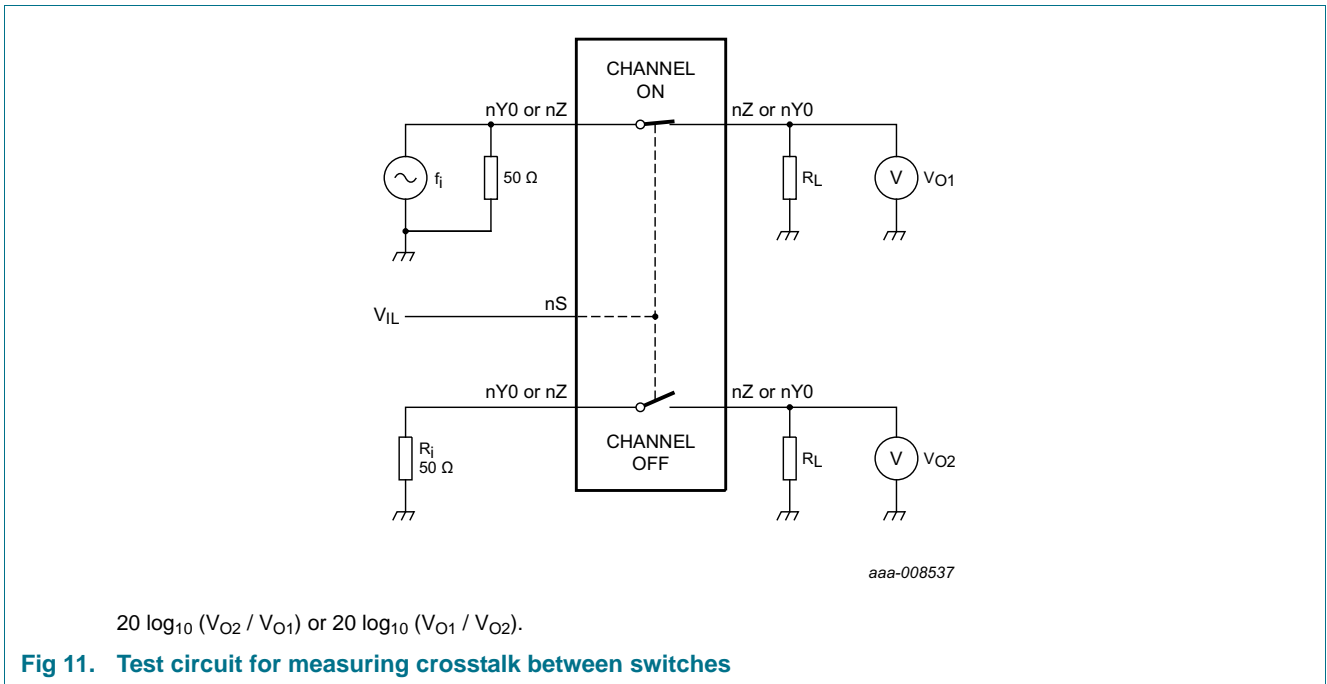

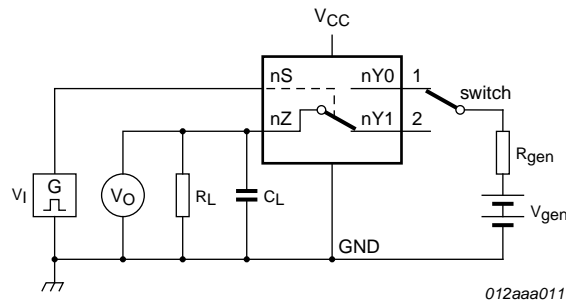

a. Test circuit

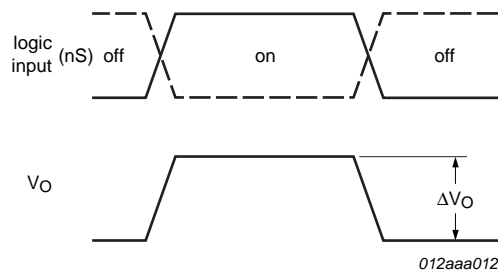

b. Input and output pulse definitions

Definition: $Q_{inj} = \Delta V_O \times C_L$.

ΔV_O = output voltage variation.

R_{gen} = generator resistance.

V_{gen} = generator voltage.

Fig 12. Test circuit for measuring charge injection

13. Package outline

XQFN10: plastic, extremely thin quad flat package; no leads; 10 terminals; body 1.40 x 1.80 x 0.50 mm

SOT1160-1

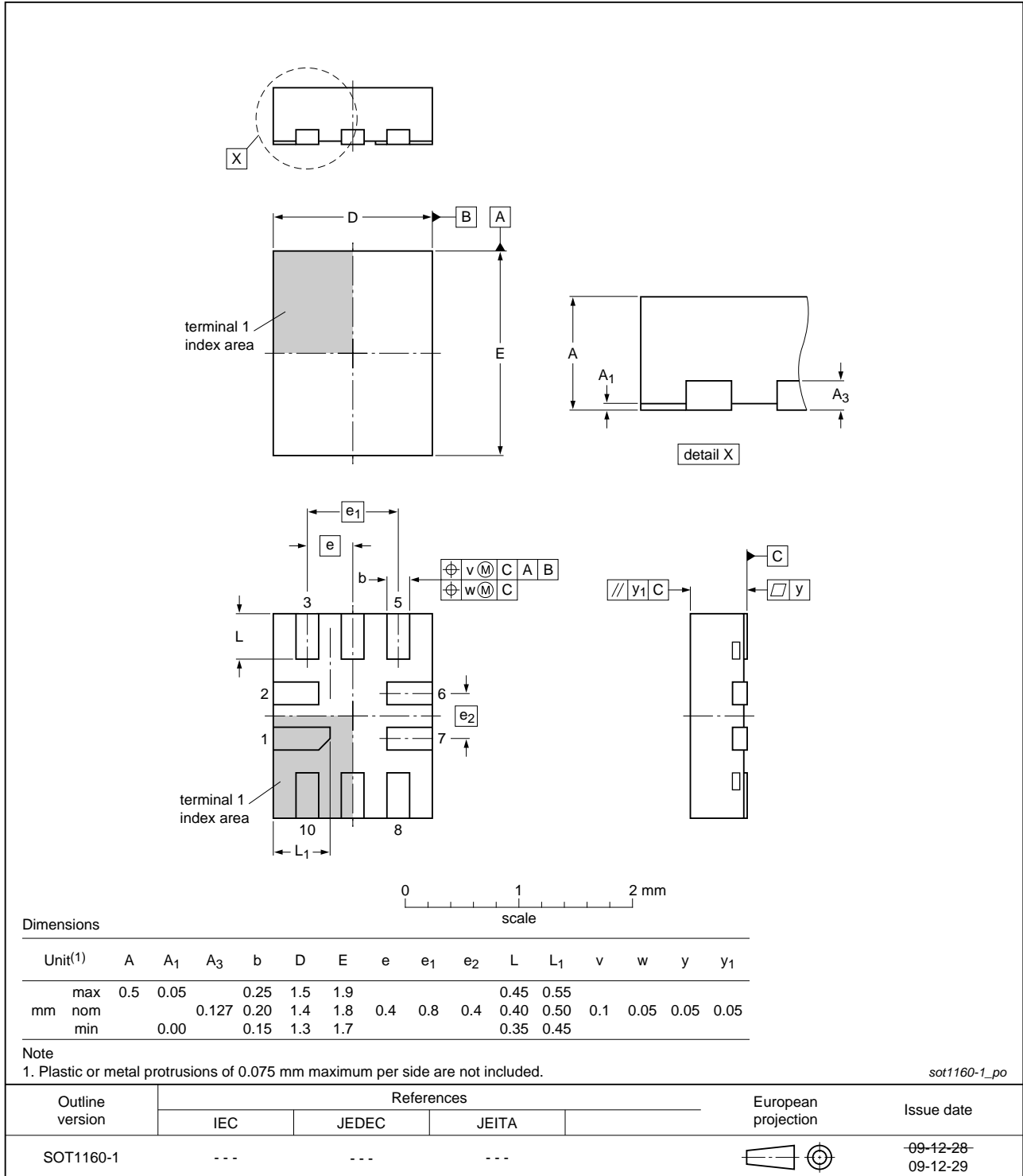

Fig 13. Package outline SOT1160-1 (XQFN10)

14. Abbreviations

Table 13. Abbreviations

Acronym	Description
CDM	Charged Device Model
CMOS	Complementary Metal-Oxide Semiconductor
ESD	ElectroStatic Discharge
HBM	Human Body Model
MM	Machine Model
TTL	Transistor-Transistor Logic
UART	Universal Asynchronous Receiver/Transmitter
USB	Universal Serial Bus

15. Revision history

Table 14. Revision history

Document ID	Release date	Data sheet status	Change notice	Supersedes
NX5L2750C v.1	20130906	Product data sheet	-	-

16. Legal information

16.1 Data sheet status

Document status ^{[1][2]}	Product status ^[3]	Definition
Objective [short] data sheet	Development	This document contains data from the objective specification for product development.
Preliminary [short] data sheet	Qualification	This document contains data from the preliminary specification.
Product [short] data sheet	Production	This document contains the product specification.

[1] Please consult the most recently issued document before initiating or completing a design.

[2] The term 'short data sheet' is explained in section "Definitions".

[3] The product status of device(s) described in this document may have changed since this document was published and may differ in case of multiple devices. The latest product status information is available on the Internet at URL <http://www.nxp.com>.

16.2 Definitions

Draft — The document is a draft version only. The content is still under internal review and subject to formal approval, which may result in modifications or additions. NXP Semiconductors does not give any representations or warranties as to the accuracy or completeness of information included herein and shall have no liability for the consequences of use of such information.

Short data sheet — A short data sheet is an extract from a full data sheet with the same product type number(s) and title. A short data sheet is intended for quick reference only and should not be relied upon to contain detailed and full information. For detailed and full information see the relevant full data sheet, which is available on request via the local NXP Semiconductors sales office. In case of any inconsistency or conflict with the short data sheet, the full data sheet shall prevail.

Product specification — The information and data provided in a Product data sheet shall define the specification of the product as agreed between NXP Semiconductors and its customer, unless NXP Semiconductors and customer have explicitly agreed otherwise in writing. In no event however, shall an agreement be valid in which the NXP Semiconductors product is deemed to offer functions and qualities beyond those described in the Product data sheet.

16.3 Disclaimers

Limited warranty and liability — Information in this document is believed to be accurate and reliable. However, NXP Semiconductors does not give any representations or warranties, expressed or implied, as to the accuracy or completeness of such information and shall have no liability for the consequences of use of such information. NXP Semiconductors takes no responsibility for the content in this document if provided by an information source outside of NXP Semiconductors.

In no event shall NXP Semiconductors be liable for any indirect, incidental, punitive, special or consequential damages (including - without limitation - lost profits, lost savings, business interruption, costs related to the removal or replacement of any products or rework charges) whether or not such damages are based on tort (including negligence), warranty, breach of contract or any other legal theory.

Notwithstanding any damages that customer might incur for any reason whatsoever, NXP Semiconductors' aggregate and cumulative liability towards customer for the products described herein shall be limited in accordance with the *Terms and conditions of commercial sale* of NXP Semiconductors.

Right to make changes — NXP Semiconductors reserves the right to make changes to information published in this document, including without limitation specifications and product descriptions, at any time and without notice. This document supersedes and replaces all information supplied prior to the publication hereof.

Suitability for use — NXP Semiconductors products are not designed, authorized or warranted to be suitable for use in life support, life-critical or safety-critical systems or equipment, nor in applications where failure or malfunction of an NXP Semiconductors product can reasonably be expected to result in personal injury, death or severe property or environmental damage. NXP Semiconductors and its suppliers accept no liability for inclusion and/or use of NXP Semiconductors products in such equipment or applications and therefore such inclusion and/or use is at the customer's own risk.

Applications — Applications that are described herein for any of these products are for illustrative purposes only. NXP Semiconductors makes no representation or warranty that such applications will be suitable for the specified use without further testing or modification.

Customers are responsible for the design and operation of their applications and products using NXP Semiconductors products, and NXP Semiconductors accepts no liability for any assistance with applications or customer product design. It is customer's sole responsibility to determine whether the NXP Semiconductors product is suitable and fit for the customer's applications and products planned, as well as for the planned application and use of customer's third party customer(s). Customers should provide appropriate design and operating safeguards to minimize the risks associated with their applications and products.

NXP Semiconductors does not accept any liability related to any default, damage, costs or problem which is based on any weakness or default in the customer's applications or products, or the application or use by customer's third party customer(s). Customer is responsible for doing all necessary testing for the customer's applications and products using NXP Semiconductors products in order to avoid a default of the applications and the products or of the application or use by customer's third party customer(s). NXP does not accept any liability in this respect.

Limiting values — Stress above one or more limiting values (as defined in the Absolute Maximum Ratings System of IEC 60134) will cause permanent damage to the device. Limiting values are stress ratings only and (proper) operation of the device at these or any other conditions above those given in the Recommended operating conditions section (if present) or the Characteristics sections of this document is not warranted. Constant or repeated exposure to limiting values will permanently and irreversibly affect the quality and reliability of the device.

Terms and conditions of commercial sale — NXP Semiconductors products are sold subject to the general terms and conditions of commercial sale, as published at <http://www.nxp.com/profile/terms>, unless otherwise agreed in a valid written individual agreement. In case an individual agreement is concluded only the terms and conditions of the respective agreement shall apply. NXP Semiconductors hereby expressly objects to applying the customer's general terms and conditions with regard to the purchase of NXP Semiconductors products by customer.

No offer to sell or license — Nothing in this document may be interpreted or construed as an offer to sell products that is open for acceptance or the grant, conveyance or implication of any license under any copyrights, patents or other industrial or intellectual property rights.

Export control — This document as well as the item(s) described herein may be subject to export control regulations. Export might require a prior authorization from competent authorities.

Non-automotive qualified products — Unless this data sheet expressly states that this specific NXP Semiconductors product is automotive qualified, the product is not suitable for automotive use. It is neither qualified nor tested in accordance with automotive testing or application requirements. NXP Semiconductors accepts no liability for inclusion and/or use of non-automotive qualified products in automotive equipment or applications.

In the event that customer uses the product for design-in and use in automotive applications to automotive specifications and standards, customer (a) shall use the product without NXP Semiconductors' warranty of the product for such automotive applications, use and specifications, and (b) whenever customer uses the product for automotive applications beyond

NXP Semiconductors' specifications such use shall be solely at customer's own risk, and (c) customer fully indemnifies NXP Semiconductors for any liability, damages or failed product claims resulting from customer design and use of the product for automotive applications beyond NXP Semiconductors' standard warranty and NXP Semiconductors' product specifications.

Translations — A non-English (translated) version of a document is for reference only. The English version shall prevail in case of any discrepancy between the translated and English versions.

16.4 Trademarks

Notice: All referenced brands, product names, service names and trademarks are the property of their respective owners.

17. Contact information

For more information, please visit: <http://www.nxp.com>

For sales office addresses, please send an email to: salesaddresses@nxp.com

18. Contents

1 **General description** 1

2 **Features and benefits** 1

3 **Applications** 1

4 **Ordering information** 2

5 **Marking** 2

6 **Functional diagram** 2

7 **Pinning information** 2

7.1 Pinning 2

7.2 Pin description 3

8 **Functional description** 3

9 **Limiting values** 3

10 **Recommended operating conditions** 4

11 **Static characteristics** 4

11.1 Test circuits 5

11.2 ON resistance 5

11.3 ON resistance test circuit and graphs 5

12 **Dynamic characteristics** 6

12.1 Waveform and test circuits 6

12.2 Additional dynamic characteristics 8

12.3 Test circuits 8

13 **Package outline** 12

14 **Abbreviations** 13

15 **Revision history** 13

16 **Legal information** 14

16.1 Data sheet status 14

16.2 Definitions 14

16.3 Disclaimers 14

16.4 Trademarks 15

17 **Contact information** 15

18 **Contents** 16

Please be aware that important notices concerning this document and the product(s) described herein, have been included in section 'Legal information'.